

PRODUCT DATA

7 07 10 00 **Dampproofing & Waterproofing**

SONOSHIELD® DBS 2000, 6000, 6200, AND 9000

Polypropylene drain board systems

Description

DBS 2000, 6000, 6200, and 9000 constitute a series of polypropylene drain board systems that significantly reduce the amount of water coming into contact with the waterproofing membranes, relieve hydrostatic pressure, and extend the life of the waterproofing system.

SONOSHIELD® DBS 2000

A cost-effective, high-strength polymeric core and non-woven geotextile filter fabric for vertical installations at shallower depths where moderate compressive strengths and flow capacity are adequate.

SONOSHIELD® DBS 6000 AND 6200

Offers the ultimate in vertical drain solutions. DBS 6200 incorporates a plastic sheet adhered to the back surface of the drain core, offering a protective layer that prevents die cutting of the waterproofing membrane.

SONOSHIELD® DBS 9000

A high-strength drain board ideally suited for horizontal applications. DBS 9000 utilizes a high-strength woven monofilament filter fabric that offers ideal drainage and support under concrete, soil, and beddings.

Yield

DBS 2000, 6000, and 6200:
200 ft² (18 m²) per 4 by 50 ft (1.2 by 15.2 m) roll

DBS 9000:
300 ft² (27 m²) per 6 by 50 ft (1.8 by 15.2 m) roll

Features

- High-impact polypropylene core
- Dimpled core construction
- Fully bonded geotextile fabric
- Water-flow control

Benefits

- Provides the toughest drain system available
- Produces high water-flow rates
- Prevents blockage of the core
- Relieves hydrostatic pressure on buildings; extends the life of waterproofing systems

Packaging

DBS 2000, 6000, and 6200:
4 by 50 ft (1.2 by 15.2 m) rolls

DBS 9000:
6 by 50 ft (1.8 by 15.2 m) rolls

Color

Black

Where to Use

Sonoshield® DBS 2000

APPLICATION

- Retaining walls
- Tunnel construction
- Bridge abutments

LOCATION

- Vertical substrates

Sonoshield® DBS 6000 and 6200

APPLICATION

- Foundation walls
- Plaza decks
- Planter boxes
- Lagging walls

LOCATION

- Below grade with HLM® 5000
- Vertical and horizontal substrates

Sonoshield® DBS 9000

APPLICATION

- Plaza decks
- Planter boxes
- Garden roofs and terraces
- Split-lab construction
- Parking decks

LOCATION

- Horizontal substrates

How to Install

Surface Preparation

Surfaces to receive drain board should be relatively smooth and free of sharp or protruding objects.

Installation

INSTALLATION ON VERTICAL SURFACES—
DBS 2000, 6000, AND 6200

1. Install DBS 2000, 6000 and 6200 with the filter fabric side facing away from the wall so that backfill will be placed against the fabric. Cut panels to appropriate size using utility knife or scissors.

Technical Data

Typical Properties

PROPERTY	VALUE
Roll weight, lbs (kg)	
DBS 2000	56 (25)
DBS 6000	63 (29)
DBS 6200	64 (29)
DBS 9000	70 (32)
Material (filter fabric)	
DBS 2000	Nonwoven PP *
DBS 6000, 6200	Nonwoven PP *
DBS 9000	Woven PP *

* PP - Polypropylene

Test Data

PROPERTY	RESULTS	TEST METHODS
Core weight, oz/ft² (g/m²)		ASTM D 3776
DBS 2000	2.45 (750)	
DBS 6000, 6200	2.75 (830)	
DBS 9000	3.05 (930)	
Compressive strength, psf (kN/m²)		ASTM D 1621, modified
DBS 2000	11,000 (550)	
DBS 6000, 6200	15,100 (723)	
DBS 9000	18,000 (862)	
Thickness, in (mm)		ASTM D 1777
DBS 2000	0.40 (10)	
DBS 6000, 6200	0.40 (10)	
DBS 9000	0.40 (10)	

FILTER FABRIC PROPERTIES—MINIMUM AVERAGE ROLL VOLUME

PROPERTY	RESULTS	TEST METHODS
Grab tensile, lbs (N)		ASTM D 4632
DBS 2000	110 (0.49)	
DBS 6000, 6200	110 (0.49)	
DBS 9000	365 (1.62)	
Elongation, %		ASTM D 4632
DBS 2000	50	
DBS 6000, 6200	50	
DBS 9000	24	
Trapezoidal tear, lbs (N)		ASTM D 4533
DBS 2000	50 (0.22)	
DBS 6000, 6200	50 (0.22)	
DBS 9000	115 (0.511)	
Puncture strength, lbs (N)		ASTM D 4833
DBS 2000	65 (0.29)	
DBS 6000, 6200	65 (0.29)	
DBS 9000	105 (0.47)	
Mullen burst, psi (kPa)		ASTM D 3786
DBS 2000	215 (1,482)	
DBS 6000, 6200	215 (1,482)	
DBS 9000	480 (3,304)	
Apparent opening size, sieve size (mm)		ASTM D 4751
DBS 2000	70 (0.21)	
DBS 6000, 6200	70 (0.21)	
DBS 9000	40 (0.42)	
Permittivity, sec⁻¹ (sec⁻¹)		ASTM D 4491
DBS 2000	2.0 (2.0)	
DBS 6000, 6200	2.0 (2.0)	
DBS 9000	1.36 (1.36)	
Water flow rate, gpm/ft² (L/min/m²)		ASTM D 4491
DBS 2000	140 (5690)	
DBS 6000, 6200	140 (5690)	
DBS 9000	100 (4074)	
Weight typical, oz/yd² (g/m²)		ASTM D 5261
DBS 2000	4.0 (135)	
DBS 6000, 6200	4.0 (135)	
DBS 9000	6.5 (216)	

Test Data (continued)

FILTER FABRIC PROPERTIES—MINIMUM AVERAGE ROLL VOLUME

PROPERTY	RESULTS	TEST METHODS
UV resistance, % (500 hrs)		ASTM D 4355
DBS 2000	70	
DBS 6000, 6200	70	
DBS 9000	70	

COMPOSITE SYSTEM

PROPERTY	RESULTS	TEST METHODS
Water-flow rate (V), gal/min/ft (L/min/m)		ASTM D 4716
DBS 2000	18 (223)	
DBS 6000, 6200	18 (223)	
DBS 9000	27 (334)	
Water-flow rate (H), gal/min/ft (L/min/m)		ASTM D 4716
DBS 6000, 6200	3.2 (40)	
DBS 9000	5.4 (67)	

2. To install all panels, use a suitable bonding system that is compatible with the substrate. Typical installation of DBS 2000 or 6200 over a cured waterproof membrane requires using an adhesive, two-sided mastic tape or a suitable Sonolastic® sealant to hold the board in place. Backfilling at the end of installation completes the permanent placement.

3. To install DBS panels longitudinally, start the first lift of drain panel at the bottom of the application area to ensure sound drainage. Install the next lift of drain panel by overlapping the panel's flat tab section onto the previously installed drain board. Complete the attachment by pulling the excess filter fabric down over the previously installed DBS panel. This installation method will automatically create a step-down (shingle fashion) lap to properly drain water. Enclose all ends of the drainage panel with the attached fabric. Wrap the fabric over top drain board to prevent earth infiltration. The bottom of the DBS panel should be placed behind the discharge pipe.

4. To install DBS panels vertically, follow the same procedure for overlapping the panels. Work from one side of the application area to the other, keeping the fabric side out and the lap consistent.

5. Ensure that fabric covers all exposed core edges.

6. Place backfill as soon as possible after DBS installation. Take care not to damage DBS during backfilling.

INSTALLATION ON HORIZONTAL SURFACES—

DBS 6000, 6200 AND 9000

1. The substrate below the DBS 6000, 6200, and 9000 panel should have a minimum 2% slope.
2. Install DBS with the filter fabric side up.
3. Adhere the DBS at 10 ft (3.3 m) centers using two-sided mastic tape when necessary.
4. Overlap the sheets using the flat tab sections of each. Overlap the fabric onto the preceding panel and adhere the overlapped fabric with adhesive tape if necessary to prevent soil, sand, and concrete from entering the DBS panel during construction.
5. Start DBS installations at the lowest point to ensure sound drainage and to create a shingling effect in the installation.
6. Overlapping of DBS 6000, 6200 and 9000 panels in horizontal installations must take slope and water flow into account. DBS panels must be shingled in the direction of the water flow using sound waterproofing practices.
7. Ensure that fabric covers all exposed core edges.
8. Place backfill as soon as possible after DBS installation. Take care not to damage DBS during backfilling.

For Best Performance

- Do not expose DBS rolls to direct sunlight for prolonged periods.
- Ensure any exposed core area is covered with filter fabric.
- Repair tears or holes in the fabric by placing new cloth over damaged areas.

- In horizontal applications where reinforcing steel is to be placed, spread foot type rebar chairs or wide plastic bar holders are recommended. Repair any damage caused during steel installation.
- When the DBS panels are cut around termination protrusions or planter installations, be sure to cover all cut areas with extra pieces of filter fabric to prevent intrusion. Cut sections generally require a 4 – 6" (100 – 150 mm) overlap.
- Use scissors or utility knives to cut DBS. For cutting entire rolls, a cut-off saw with a carbide blade is recommended.
- Protect the installation's finished surface from damage by rocks or debris during construction and backfilling.
- Backfill should be placed as soon as possible after DBS installation.
- DBS 2000, 6000, 6200, and 9000 are made from highly chemical-resistant polypropylene and are suitable for use in a variety of applications. For specific chemical environments, contact BASF Technical Service to determine suitability.
- Make certain the most current versions of product data sheet and MSDS are being used; call Customer Service (1-800-433-9517) to verify the most current versions.
- Proper application is the responsibility of the user. Field visits by BASF personnel are for the purpose of making technical recommendations only and not to supervise or provide quality control on the job site.

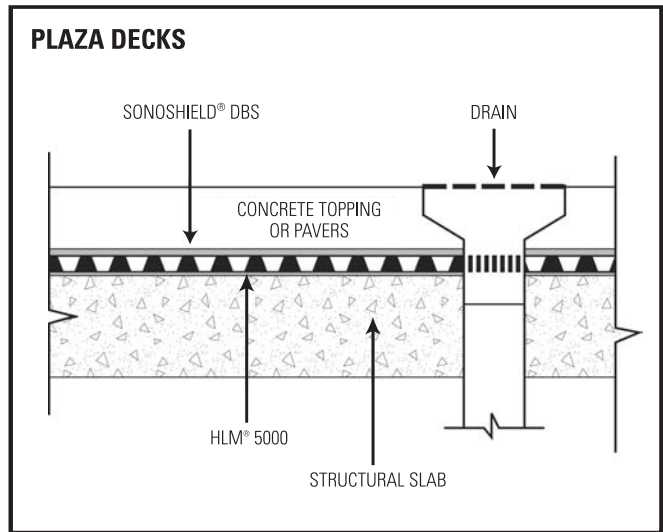
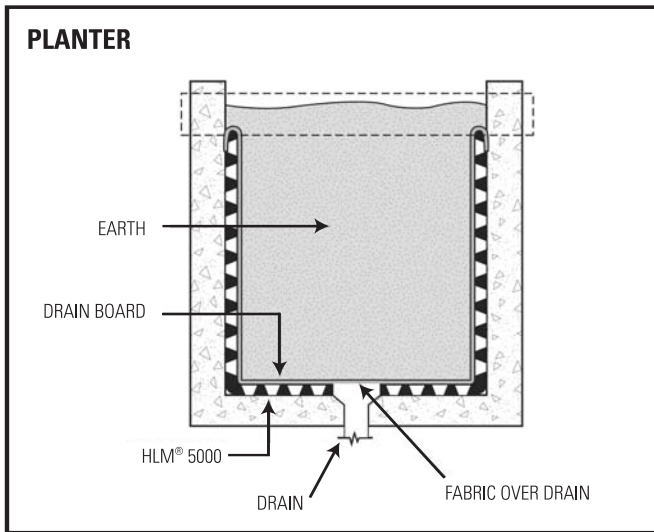
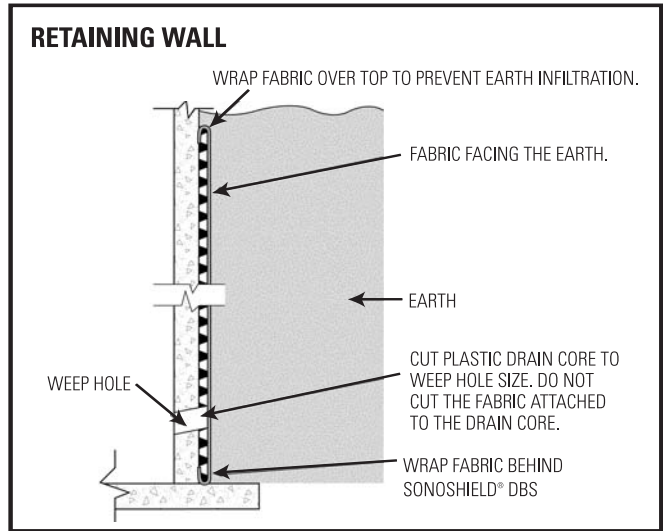
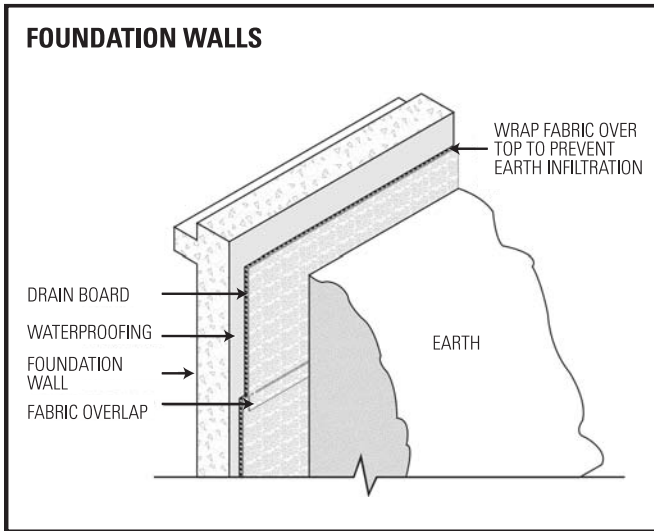

BASF Construction Chemicals, LLC – Building Systems

889 Valley Park Drive
 Shakopee, MN, 55379

www.BuildingSystems.BASF.com

Customer Service 800-433-9517
Technical Service 800-243-6739



LIMITED WARRANTY NOTICE: Every reasonable effort is made to apply BASF exacting standards both in the manufacture of our products and in the information which we issue concerning these products and their use. We warrant our products to be of good quality and will replace or, at our election, refund the purchase price of any products proved defective. Satisfactory results depend not only upon quality products, but also upon many factors beyond our control. Therefore, except for such replacement or refund, BASF MAKES NO WARRANTY OR GUARANTEE, EXPRESS OR IMPLIED, INCLUDING WARRANTIES OF FITNESS FOR A PARTICULAR PURPOSE OR MERCHANTABILITY, RESPECTING ITS PRODUCTS, and BASF shall have no other liability with respect thereto. Any claim regarding product defect must be received in writing within one (1) year from the date of shipment. No claim will be considered without such written notice or after the specified time interval. User shall determine the suitability of the products for the intended use and assume all risks and liability in connection therewith. Any authorized change in the printed recommendations concerning the use of our products must bear the signature of the BASF Technical Manager.

This information and all further technical advice are based on BASF's present knowledge and experience. However, BASF assumes no liability for providing such information and advice including the extent to which such information and advice may relate to existing third party intellectual property rights, especially patent rights. In particular, BASF disclaims all CONDITIONS AND WARRANTIES, WHETHER EXPRESS OR IMPLIED, INCLUDING THE IMPLIED WARRANTIES OF FITNESS FOR A PARTICULAR PURPOSE OR MERCHANTABILITY. BASF SHALL NOT BE RESPONSIBLE FOR CONSEQUENTIAL, INDIRECT OR INCIDENTAL DAMAGES (INCLUDING LOSS OF PROFITS) OF ANY KIND. BASF reserves the right to make any changes according to technological progress or further developments. It is the customer's responsibility and obligation to carefully inspect and test any incoming goods. Performance of the product(s) described herein should be verified by testing and carried out only by qualified experts. It is the sole responsibility of the customer to carry out and arrange for any such testing. Reference to trade names used by other companies is neither a recommendation, nor an endorsement of any product and does not imply that similar products could not be used.

For professional use only. Not for sale to or use by the general public.

Form No. 1017870 9/07

Printed on recycled paper including 10% post-consumer fiber.

© 2007 BASF
 Printed in U.S.A.